

SPECIFICATIONS:

RELIEF VALVE SETTING	_____	4000-4300 PSI [275,8-296,5 BAR]
MAX. OPERATING PRESSURE	_____	4400 PSI [303,4 BAR]
RECOMMENDED OPERATING TEMP.	_____	-30°F TO 130°F [-34°C TO 54°C]
PUMP PLUNGER DIA.	_____	.69 [17,5]
PUMP PLUNGER EFFECTIVE AREA	_____	.371 SQ IN [2,39 SQ CM]
STROKE	_____	1.00 [25,4]
VOLUME PER STROKE	_____	.371 CU IN [6,08 CU CM]
RESERVOIR CAPACITY	_____	35 CU IN [574 CU CM] USEABLE
RESERVOIR VENT RELIEF SETTING	_____	50-75 PSI [3,4-5,2 BAR]
MAX. PORT FITTING TORQUE	_____	10-12 FT. LBS
PUMP RETURN DRIFICE DIA.	_____	.018 [0,46]
MAX. MOUNTING BOLT TORQUE	_____	16-19 FT LBS
MIN. MOUNTING BOLT ENGAGEMENT	_____	.50 [12,7]
RECOMMENDED FLUID	_____	PER MIL-H-5606 OR EQUIV. DO NOT USE ATF
WEIGHT	_____	5.3 LBS [2,4 kg]
CORROSION RESISTANCE	_____	250 HRS PER ASTM B117
PAINT SPECIFICATIONS	_____	SEMI-GLOSS BLACK

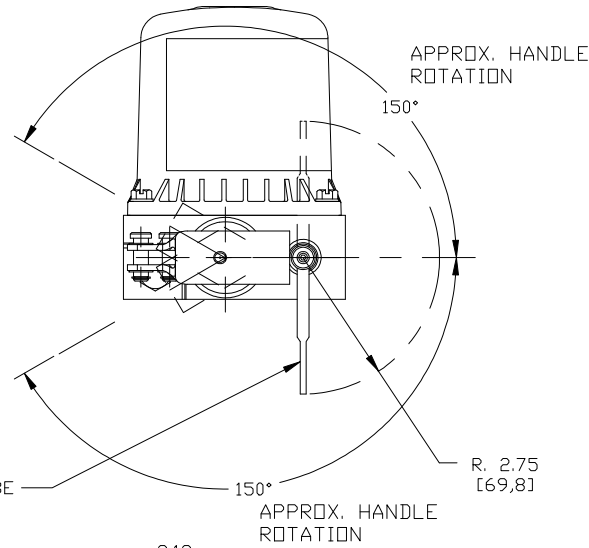

RAISE / LOWER SHIFT LEVER TO BE IN "LOWER" POSITION, AS SHOWN DURING VEHICLE OPERATION.

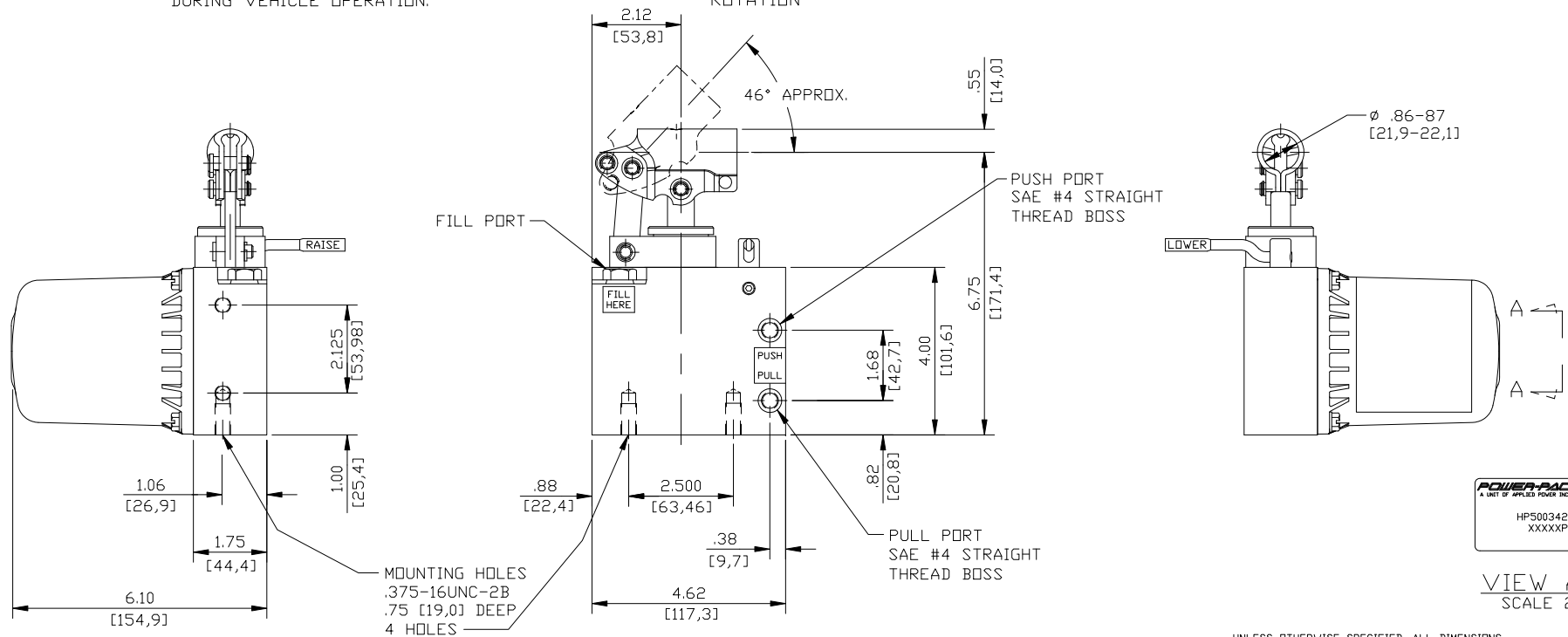

VIEW A-A
SCALE 2:1

UNLESS OTHERWISE SPECIFIED, ALL DIMENSIONS ARE NOMINAL AND MAY VARY DUE TO MANUFACTURING TOLERANCES AND ASSEMBLY TOLERANCE STACK-UP.

FILE NO. 001278

REVISED BEAM, PINS & CLIPS 014-5 J-JH 01/09/02 30516 RELEASED 10-18-94	DATE	DIMENSIONS IN BRACKETS ARE IN [mm]	POWER-PACKER A UNIT OF APPLIED POWER INC.	12801 WEST SILVERSPRING RD. BUTLER, WISCONSIN 53007
ECD	CHANGES	Specification Sheet		DESCRIPTION TILT CAB PUMP
MODEL NO.	HP50034210	DR. MP.J	DATE 10-18-94	DRAWING NO. PID 167
		CH. MP.J	DATE 10-18-94	DWG. SIZE C