

HYDRAULIC LATCHES



Safe, secure connection between two joints of a system

Our latches provide a safe, secure way to ensure covers and cabs are locked down for travel. Designed to be compact and versatile while still delivering the strength you need, our uniquely designed hydraulic latches clearly indicate when the latch is engaged.

HYDRAULIC LATCH OVERVIEW FOR UP TO 10,000 LB. VERTICAL LOAD

SECURE CONNECTION

Safely and securely create a connection between two joints of a system during operation.

VERSATILITY

The compact latch size delivers on strength, single or multiple uses, and fits into limited footprint space locations in your design.

DESIGNED FOR EASY SAFETY DETECTION

The unique design includes a latch indicator that shows when the latch is engaged.



HYDRAULIC LATCHES

Our unique, compact, user-friendly design has a visual latch indicator or an indicator switch that can be integrated into the vehicle safety system with a light or a vehicle interlock. The latch locks mechanically and releases hydraulically. Other features and benefits include:

- **Maximum vertical pull load of 10,000 pounds**
- **Maximum hydraulic pressure of 5,000 psi**
- **-30 to 130 F operating temperature**
- **Corrosion resistance of 200 hours per ANSI B1117**
- **Fluid: MIL-PRF-5606 or equivalent**
- **Design includes one of these latch indicators:**
 - **Visual indicator**
 - **Proximity switch**
 - **Electrical positional indicator switch**

Why Choose Power-Packer Hydraulic Latches

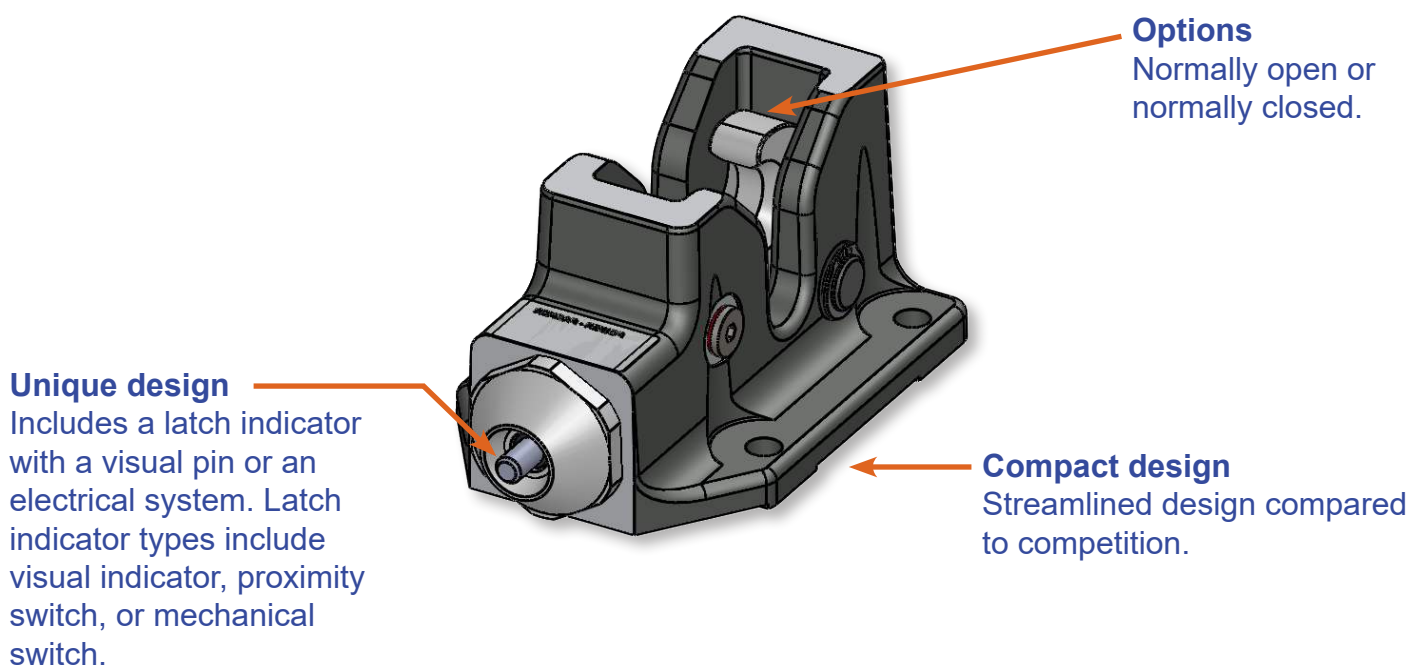

HYDRAULIC LATCHES

Hydraulic Latches													
Part Number	Description	Height		Length		Top Length		Mounting Holes	Base Dimensions		Indicator Type	Weight	
		in.	mm	in.	mm	in.	mm		in.	mm		lbs.	g
LH30037213	CAB LATCH	9.00	228.6	6.25	158.8	N/A	N/A	2	6.25X3.5	158.8X88.9	None	9.7	4399.84
LH30037220	CAB LATCH	9.00	228.6	5.50	139.7	N/A	N/A	4	5.5X4	139.7X101.6	None	10.2	4608.49
LH30037221	CAB LATCH	10.80	274.3	5.50	139.7	N/A	N/A	4	5.5X4	139.7X101.6	None	12.8	5805.98
LH30037230	CAB LATCH	9.60	243.8	5.50	139.7	N/A	N/A	5	5.5X4	139.7X101.6	None	12.8	5805.98
LH30037232	CAB LATCH	9.00	228.6	6.25	158.8	N/A	N/A	2	6.25X3.5	158.8X88.9	None	9.7	4399.84
LH30037233	CAB LATCH	9.00	228.6	6.25	158.8	N/A	N/A	2	6.25X3.5	158.8X88.9	None	9.7	4399.84
LH30037235	CAB LATCH	9.65	245.1	5.38	136.7	N/A	N/A	4	5.38X4	136.7X101.6	None	11.8	5352.39
LH30037236	CAB LATCH	10.15	257.8	5.38	136.7	N/A	N/A	4	5.38X4	136.7X101.6	None	12.7	5760.62
LH50000101	LATCH ASM VISUAL INDICATOR W/ SWITCH	3.75	95.3	6.60	167.6	4.5	114.3	4	4.5X4	114.3X101.6	VISUAL INDICATOR	3.4	1542.21
LH50000102	LATCH ASM VISUAL INDICATOR OPEN FREIGHTLINER	3.20	81.3	6.60	167.6	4.5	114.3	4	4.5X4	114.3X101.6	VISUAL INDICATOR	3.6	1623.86
LH50000104	LATCH	3.20	81.3	6.60	167.6	4.5	114.3	4	4.5X4	114.3X101.6	VISUAL INDICATOR	3.4	1542.21
LH50000105	LATCH ASM WITH GREEN PAINT	3.20	81.3	6.50	165.1	4.5	114.3	4	4.5X4	114.3X101.6	VISUAL INDICATOR	3.6	1637.47
LH50000107	LATCH ASM VISUAL INDICATOR W/ SWITCH	3.20	81.3	6.50	165.1	4.5	114.3	4	4.5X4	114.3X101.6	NORMALLY ON	3.4	1542.21
LH50000108	LATCH ASM VISUAL INDICATOR W/ CATCH	3.50	88.9	6.50	165.1	4.5	114.3	4	4.5X4	114.3X101.6	VISUAL INDICATOR	3.4	1542.21
LH50000109	LATCH, PACKARD CONNECTOR	3.20	81.3	6.50	165.1	4.5	114.3	4	4.5X4	114.3X101.6	NORMALLY ON PACKARD CONNECTOR	3.4	1542.21
LH50000111	LATCH ASM VISUAL INDICATOR W/CATCH & FITTINGS	3.20	81.3	6.50	165.1	4.5	114.3	4	4.5X4	114.3X101.6	VISUAL INDICATOR	3.4	1542.21
LH50000112	LATCH ASM VISUAL INDICATOR AND BRACKET	3.53	89.7	6.50	165.1	4.5	114.3	4	4.5X4	114.3X101.6	VISUAL INDICATOR	4.1	1841.58
LH50000114	LATCH NORMALLY ON	3.20	81.3	6.50	165.1	4.5	114.3	4	4.5X4	114.3X101.6	VISUAL INDICATOR	3.4	1542.21

HYDRAULIC LATCHES

Hydraulic Latches													
Part Number	Description	Height		Length		Top Length		Mounting Holes	Base Dimensions		Indicator Type	Weight	
		in.	mm	in.	mm	in.	mm		in.	mm		lbs.	g
LH50000116	LATCH, PACKARD CONNECTOR	3.20	81.3	6.50	165.1	4.5	114.3	4	4.5X4	114.3X101.6	NORMALLY ON PACKARD CONNECTOR	3.4	1542.21
LH50000118	LATCH	3.20	81.3	6.50	165.1	4.5	114.3	4	4.5X4	114.3X101.6	NORMALLY CLOSED	3.4	1542.21
LH50000119	LATCH ASM VISUAL INDICATOR	3.20	81.3	6.50	165.1	4.5	114.3	4	4.5X4	114.3X101.6	NORMALLY OPEN	3.4	1542.21
LH50000123	LATCH NORMALLY CLOSED W/PROXIMITY SENSOR	3.20	81.3	6.50	165.1	4.5	114.3	4	4.5X4	114.3X101.6	NORMALLY CLOSED	3.4	1542.21
LH50000124	LATCH ASM AND SWP CONNECTOR	3.20	81.3	6.50	165.1	4.5	114.3	4	4.5X4	114.3X101.6	NORMALLY OPEN	3.6	1642.00
LH50000125	LATCH ASM, SWP CONNECTOR, AND BLEEDER	3.20	81.3	6.50	165.1	4.5	114.3	4	4.5X4	114.3X101.6	NORMALLY OPEN	3.7	1660.15
LH50000126	LATCH ASM W/ PROX SWITCH	3.20	81.3	6.50	165.1	4.5	114.3	4	4.5X4	114.3X101.6	NORMALLY OPEN	3.7	1691.90
LH50000127	LATCH ASM VISUAL INDICATOR W/ SWITCH	3.20	81.3	6.50	165.1	4.5	114.3	4	4.5X4	114.3X101.6	VISUAL INDICATOR	3.4	1542.21
LH50000129	LATCH ASM W/ TRUCK SWITCH	3.20	81.3	6.50	165.1	4.5	114.3	4	4.5X4	114.3X101.6	NORMALLY CLOSED	4.0	1814.37
LH50000132	LATCH ASM HYD	3.20	81.3	6.50	165.1	4.5	114.3	4	4.5X4	114.3X101.6	VISUAL INDICATOR	3.4	1542.21

